



PIATTAFORMA PER LAVORO AEREO AUTOCARRATA

TRUCK-MOUNTED AERIAL LIFT WORK PLATFORM

HUBARBEITSBÜHNE AUF LKW



PT180

isoli@isoli.com | www.isoli.com





DIMENSIONI / OVERALL DIMENSION / GESAMTABMESSUNGEN [mm]

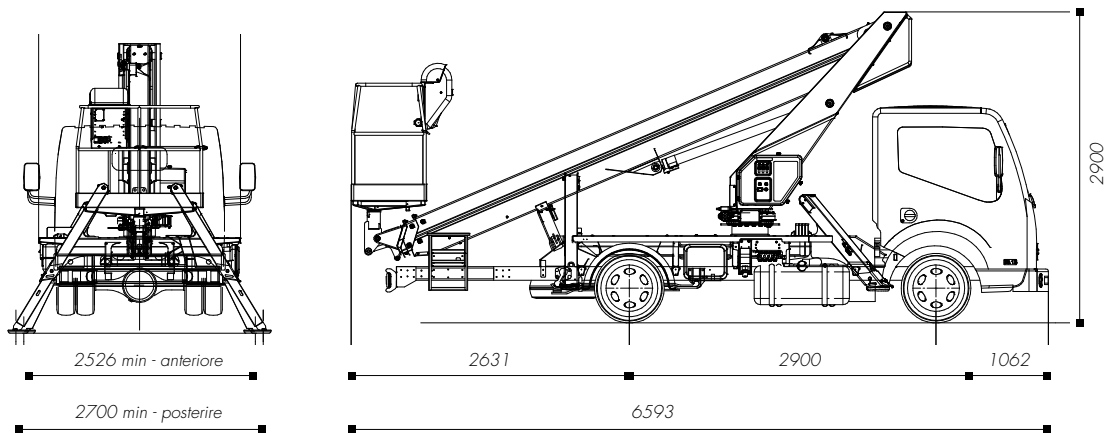

DIAGRAMMA DI LAVORO / WORKING DIAGRAM / ARBEITSDIAGRAMM [m]

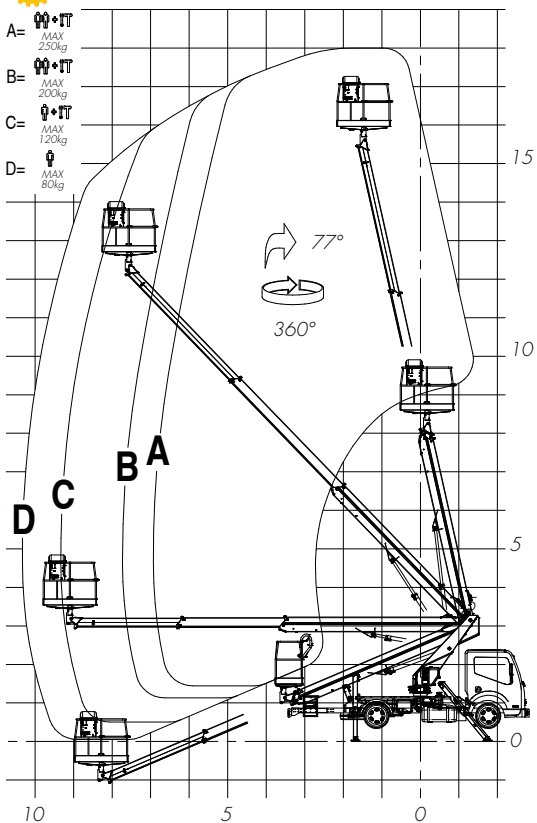

CARATTERISTICHE TECNICHE / TECHNICAL FEATURES / TECHNISCHE EIGENSCHAFTEN

	Altezza max. di lavoro Max. working height Max. Arbeitshöhe	18,00 m
	Sbraccio max. di lavoro Max. working boom extension Max. Reichweite	10,30 m
	Portata Capacity Traglast	250 Kg
	Altezza piano calpestio Walk-on surface height Korbbodenhöhe	16,00 m
	Rotazione sovrastruttura Upperstructure rotation Drehung Oberwagen	400°
	Cesta Basket Arbeitskorb	Alluminio 1400x710x1100 mm Aluminium 1400x710x1100 mm Aluminium 1400x710x1100 mm
	Rotazione cesta Basket rotation Korbschwenkung	+/- 90°
	Stabilizzatori Outriggers Abstützungen	A+A
	Comandi Controls Steuerungen	Idraulici Hydraulic Hydraulisch